

2048 x 2-pixel CCD Linear Sensor (Color)

Descriptions

The ILX522K is a reduction-type CCD linear sensor designed for color image scanner use. This sensor reads B4 size documents at a density of 200 DPI (Dots Per Inch), and has 2-line analog memories to adjust the position of the green line and the red/blue line. A built-in timing generator and clock-drivers ensure direct drive at 5V logic.

Features

- Number of effective pixels: 2048 x 2pixels
- Pixel size
 Red/Blue pixel: 14 μ m x 12 μ m (14 μ m pitch)
 Green pixel: 14 μ m x 14 μ m (14 μ m pitch)
- Built-in timing generator, clock-drivers
- Ultra-low lag
- Good linearity
- High sensitivity
- Input Clock Pulse: CMOS 5V drive

Absolute Maximum Ratings

• Supply voltage	V _{DD1}	11	V
	V _{DD2}	6	V

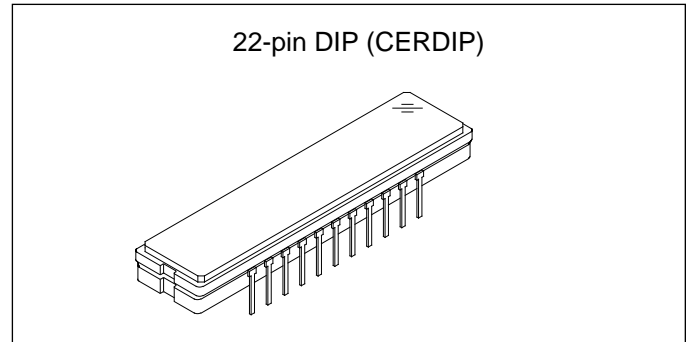

Pin Configuration (Top View)

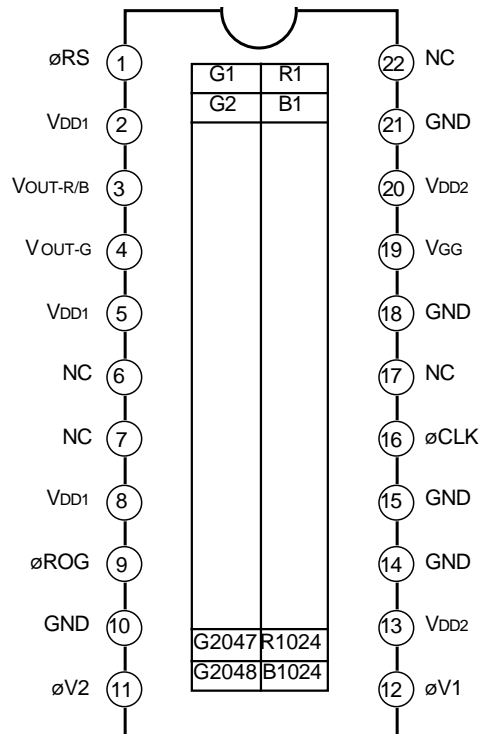

Sony reserves the right to change products and specifications without prior notice. This information does not convey any license by any implication or otherwise under any patents or other right. Application circuits shown, if any, are typical examples illustrating the operation of the devices. Sony cannot assume responsibility for any problems arising out of the use of these circuits.

Block Diagram

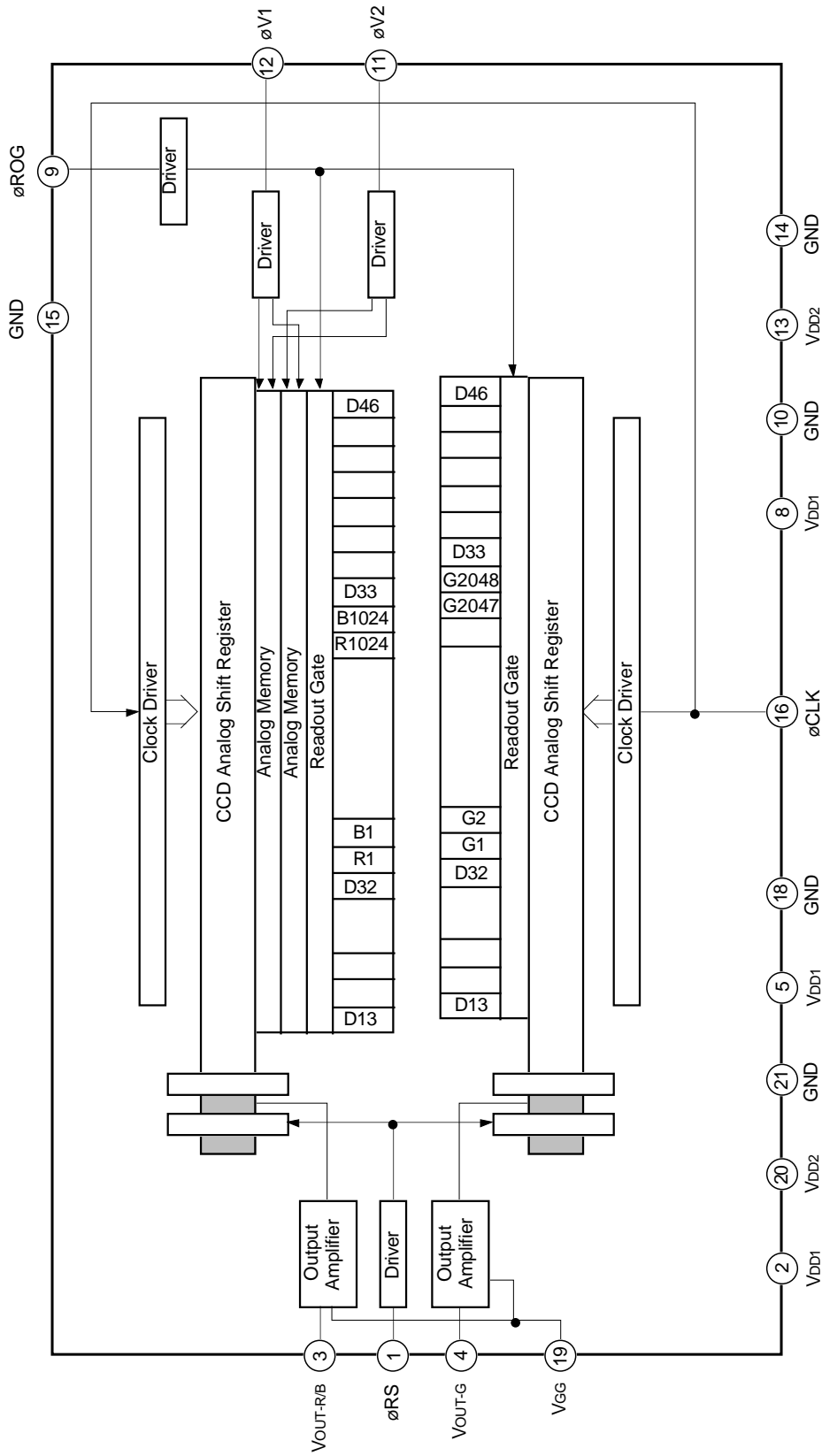

Pin Description

Pin No.	Symbol	Description
1	ϕ RS	Clock pulse input
2	V _{DD1}	9V power supply
3	V _{OUT-R/B}	R/B signal out
4	V _{OUT-G}	G signal out
5	V _{DD1}	9V power supply
6	NC	NC
7	NC	NC
8	V _{DD1}	9V power supply
9	ϕ ROG	Clock pulse input
10	GND	GND
11	ϕ V2	Clock pulse input
12	ϕ V1	Clock pulse input
13	V _{DD2}	5V power supply
14	GND	GND
15	GND	GND
16	ϕ CLK	Clock pulse input
17	NC	NC
18	GND	GND
19	V _{GG}	Output gate bias
20	V _{DD2}	5V power supply
21	GND	GND
22	NC	NC

Recommended Supply Voltage

Item	Min.	Typ.	Max.	Unit
V _{DD1}	8.5	9.0	9.5	V
V _{DD2}	4.75	5.0	5.25	V

Note: Rules for raising and lowering power supply voltage: To raise power supply voltage, first raise V_{DD1} (9V) and then V_{DD2} (5V); to lower voltage, first lower V_{DD2} (5V) and then V_{DD1} (9V).

Clock Characteristics

Item	Symbol	Min.	Typ.	Max.	Unit
Input capacity of ϕ RS, ϕ CLK	C ϕ RS, C ϕ CLK	—	10	—	pF
Input capacity of ϕ V1, ϕ V2	C ϕ V1, C ϕ V2	—	10	—	pF
Input capacity of ϕ ROG	C ϕ ROG	—	10	—	pF
Input clock frequency	f ϕ RS, f ϕ CLK	—	—	3.5	MHz

Electrical Characteristics (Note 1)

(Ta = +25°C, VDD1 = 9V, VDD2 = 5V f ϕ RS = 3.5MHz Light Source = 3200K, IR cut filter CM-500S (t = 1.0mm))

Item	Symbol	Min.	Typ.	Max.	Unit	Remarks	
Sensitivity	Red	R _R	5.2	8.0	10.8	V/(lx • s)	Note 2
	Green	R _G	6.5	10.0	13.5		
	Blue	R _B	2.8	4.3	5.8		
Sensitivity non-uniformity	PRNU	—	5.0	15.0	%	Note 3	
Saturation output voltage	V _{SAT}	1.0	1.5	—	V	Note 4	
Dark voltage average	Green	V _{DRK-G}	—	0.3	1.5	mV	Note 5
	Red/Blue	V _{DRK-R/B}	—	1.5	9.0		
Dark signal non-uniformity	Green	DSNU-G	—	0.6	3.0		
	Red/Blue	DSNU-R/B	—	2.0	12.0		
Image lag	IL	—	0.02	—	%	Note 6	
9V supply current	I _{VDD1}	—	20	40	mA	—	
5V supply current	I _{VDD2}	—	16.0	32.0	mA	—	
Total transfer efficiency	TTE	92.0	98.0	—	%	—	
Output impedance	Z _O	—	150	—	Ω	—	
Offset level	V _{OS}	—	5.4	—	V	Note 7	

Note:

- 1) In accordance with the given electro-optical characteristics, the black level is defined as the average of D3, D4, to D10.
- 2) For the sensitivity test, light is applied with a uniform intensity of illumination.
- 3) PRNU is defined as indicated below in each color. Ray incidence conditions are the same as for Note 2.

$$PRNU = \frac{(V_{MAX} - V_{MIN})/2}{V_{AVE}} \times 100 [\%]$$

The maximum output of each color is set to V_{MAX}, the minimum output to V_{MIN}, and the average output to V_{AVE}.

- 4) Use below the minimum value of the saturation output voltage.
- 5) Optical signal accumulated time τ int stands at 5ms.
- 6) V_{OUT-G} = 500mV (typ.)
- 7) V_{OS} is defined as indicated below.

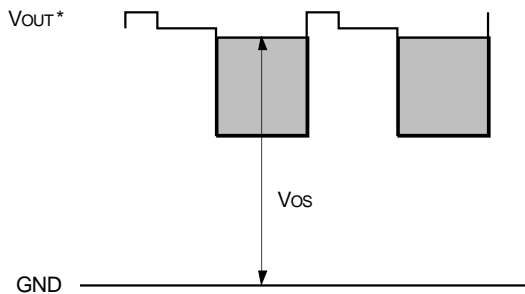

* V_{OUT} indicates V_{OUT-G} and V_{OUT-R/B}.

Clock Timing Chart

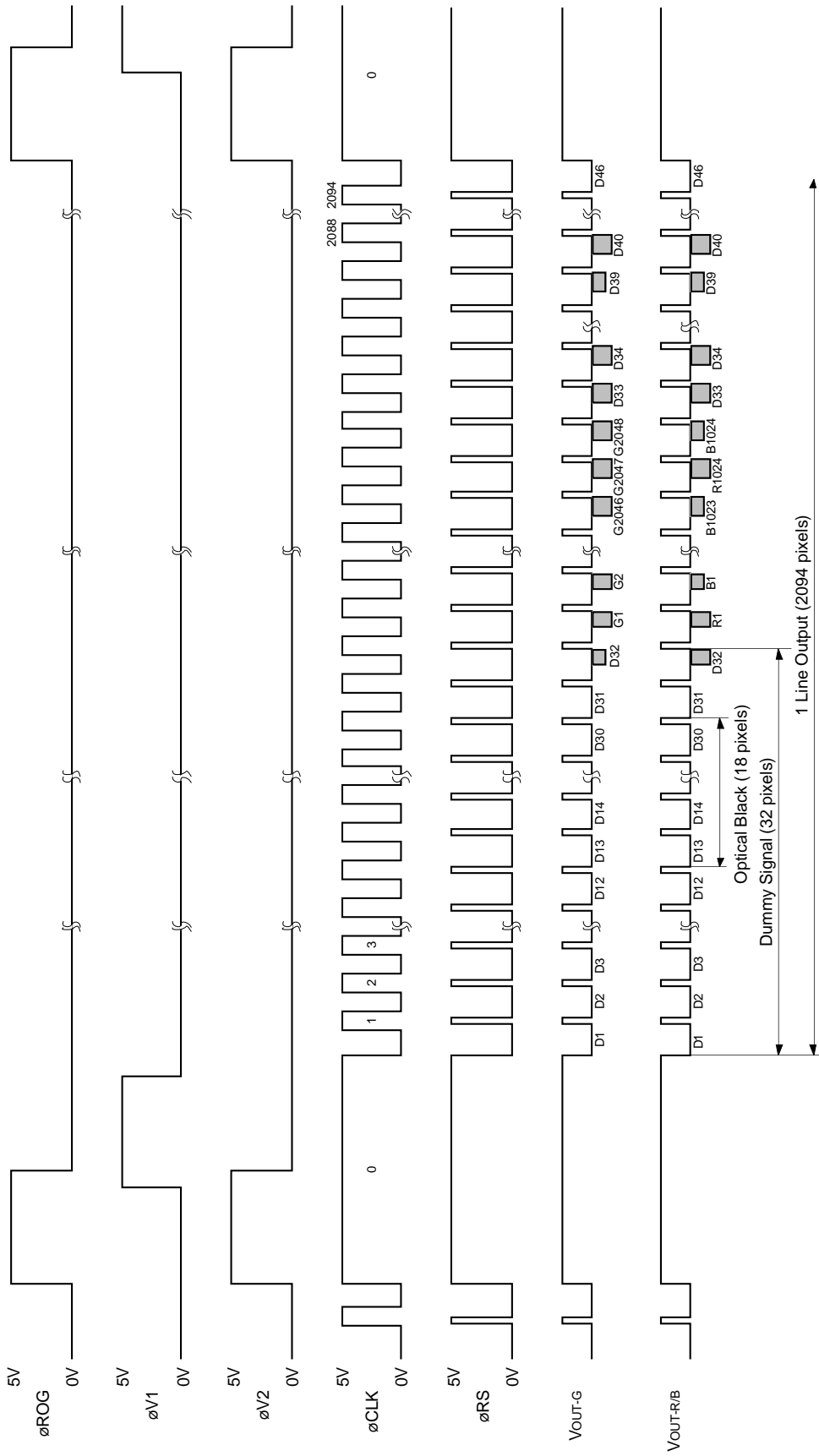

Note: φCLK, φRS pulses must have more than 2094 cycles.

ϕ ROG, ϕ V1, ϕ V2, ϕ CLK Timing

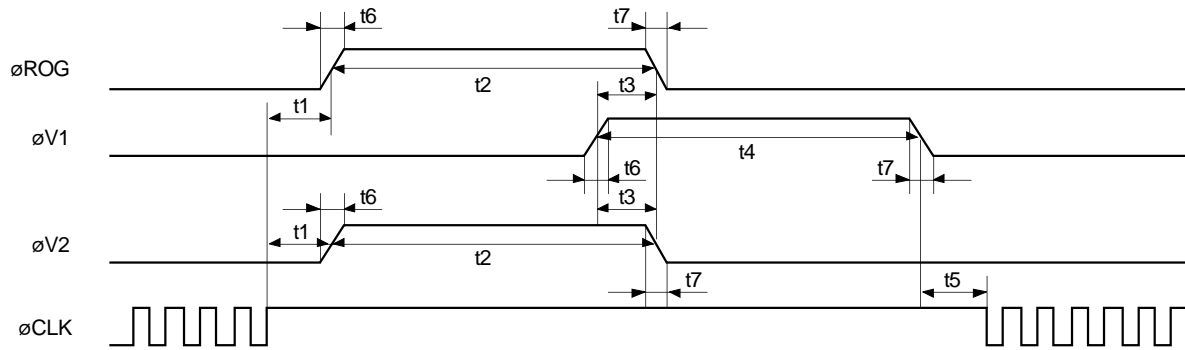

Item	Symbol	Min.	Typ.	Max.	Unit
ϕ ROG, ϕ V2 – ϕ CLK pulse timing	t1	1	2	—	μ s
ϕ ROG, ϕ V1, ϕ V2 pulse period	t2, t4	28	30	—	μ s
ϕ ROG – ϕ V1 pulse timing	t3	1	2	—	μ s
ϕ V1 – ϕ CLK pulse timing	t5	1	2	—	μ s
ϕ ROG, ϕ V1, ϕ V2 pulse rise time, fall time	t6, t7	0	10	30	ns

ϕ CLK, ϕ RS, Vout Timing

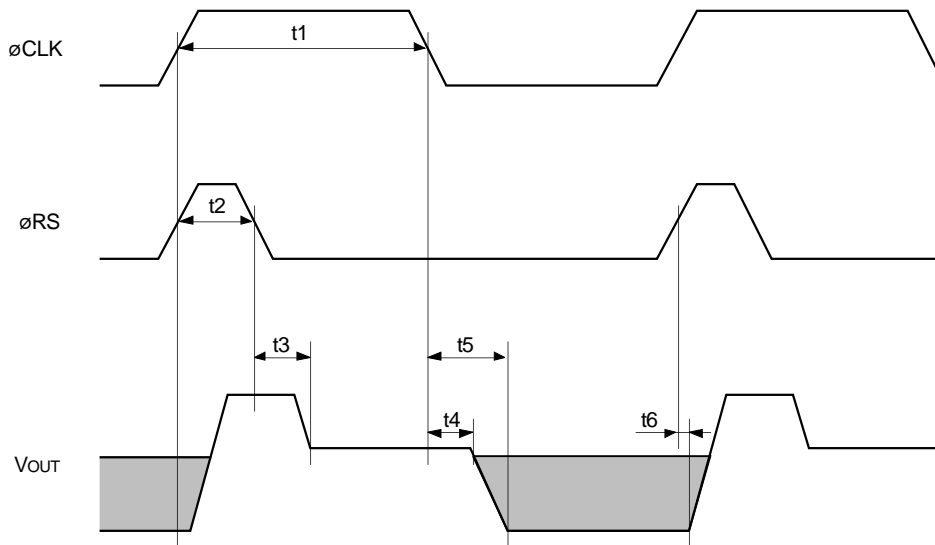

Item	Symbol	Min.	Typ.	Max.	Unit
ϕ CLK pulse high level period	t1	135	500*	—	ns
ϕ RS pulse high level period	t2	30	250*	—	ns
Signal output delay time	t3	—	60	—	ns
	t4	—	25	—	ns
	t5	—	70	—	ns
	t6	—	25	—	ns

* The timing is the condition under ϕ RS = 1MHz.

Application Circuit

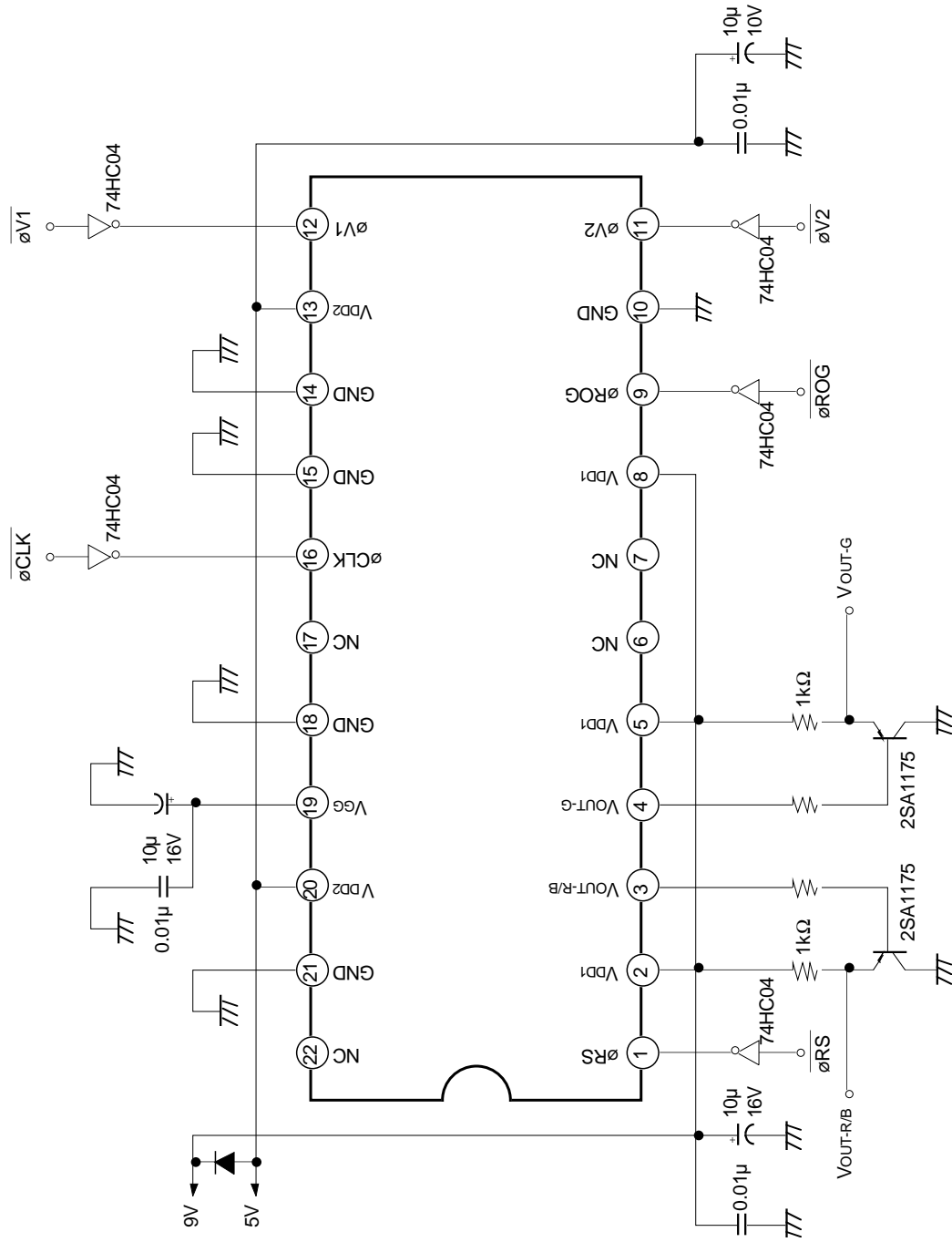

Application circuits shown are typical examples illustrating the operation of the devices. Sony cannot assume responsibility for any problems arising out of the use of these circuits or for any infringement of third party patent and other right due to same.

Example of Representative Characteristics ($V_{DD1} = 9V$, $V_{DD2} = 5V$, $T_a = +25^\circ C$)

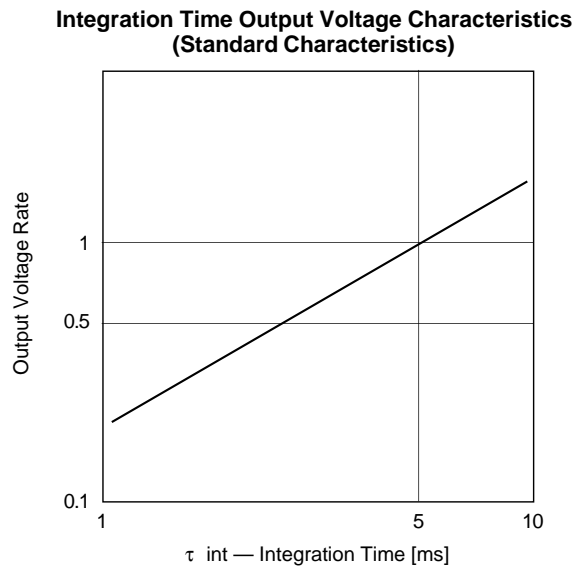
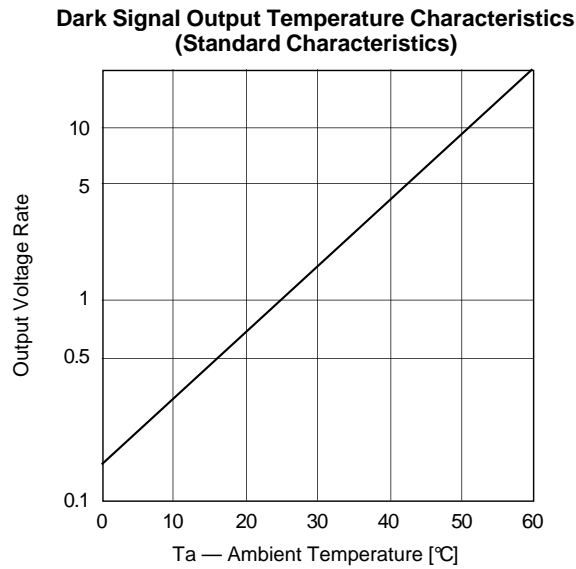
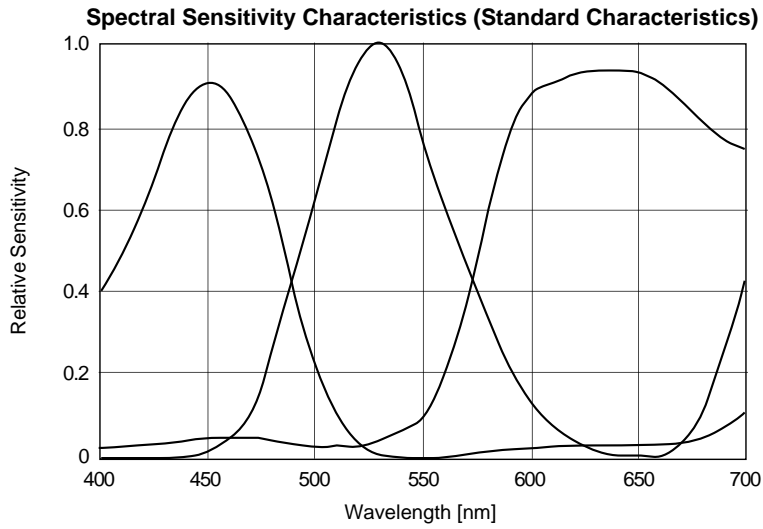

Operational Frequency Characteristics of the V_{DD1} Supply Current (Standard Characteristics)

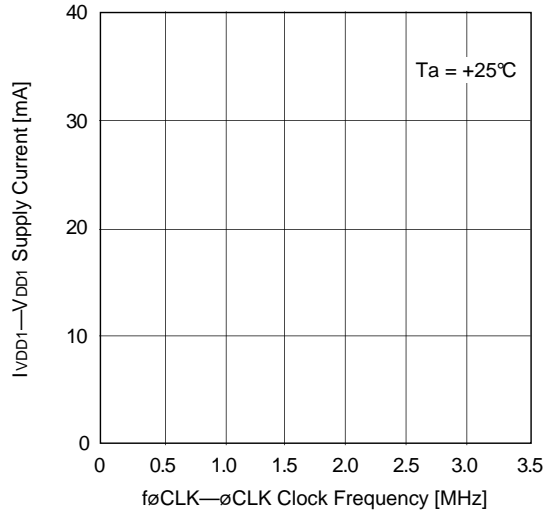

Operational Frequency Characteristics of the V_{DD2} Supply Current (Standard Characteristics)

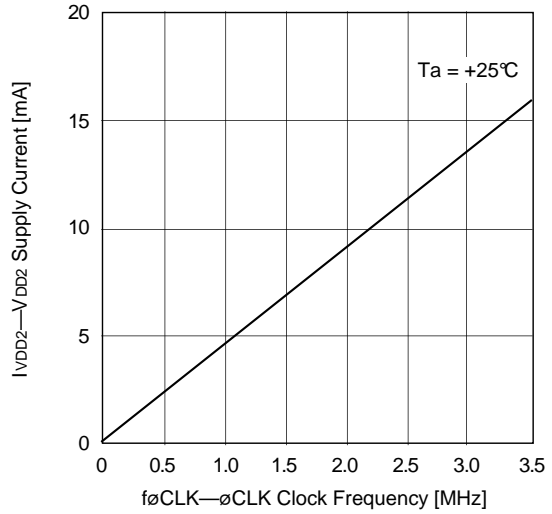

Offset Level vs. V_{DD1} Characteristics (Standard Characteristics)

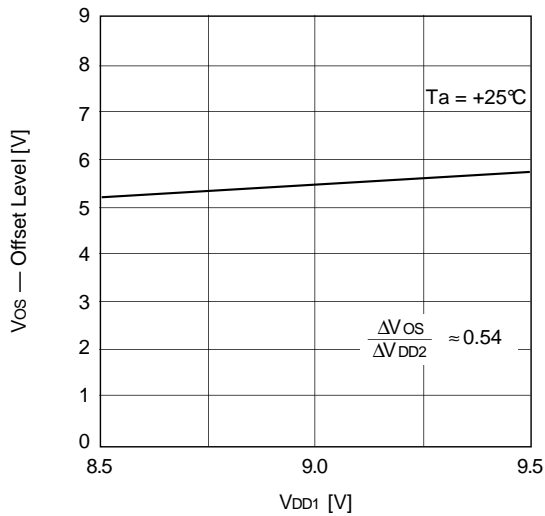

Offset Level vs. V_{DD2} Characteristics (Standard Characteristics)

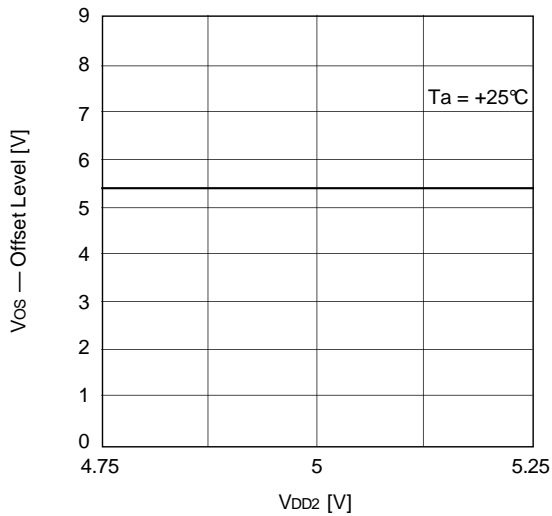

Offset Level vs. Temperature Characteristics (Standard Characteristics)

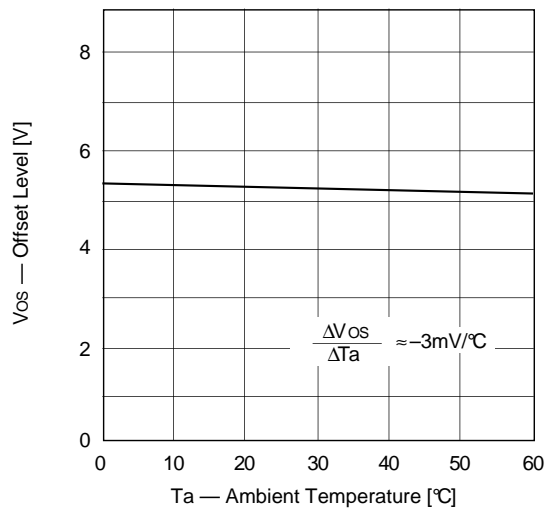

Notes of Handling

1) Static charge prevention

CCD image sensors are easily damaged by static discharge. Before handling be sure to take the following protective measures:

- a) Handle bare handed or use non-chargeable gloves, clothes or material. Also use conductive shoes.
- b) When handling directly use a grounding band.
- c) Install a conductive mat on the floor or working table to prevent the generation of static electricity.
- d) Ionized air is recommended for discharge when handling CCD image sensors.
- e) For the shipment of mounted substrates, use boxes treated for prevention of static charges.

2) Notes on handling CCD CERDIP packages

The following points should be observed when handling and installing CERDIP packages:

- a) Remain within the following limits when applying static load to the ceramic portion of the package:
 - (1) Compressive strength: 39 N/surface (do not apply load more than 0.7mm inside the outer perimeter of the glass portion)
 - (2) Shearing strength: 29 N/surface
 - (3) Tensile strength: 29 N/surface
 - (4) Torsional strength: 0.9 Nm
- b) In addition, if a load is applied to the entire surface by a hard component, bending stress may be generated and the package may fracture, etc., depending on the flatness of the ceramic portion. Therefore, for installation, either use an elastic load, such as a spring plate, or an adhesive.
- c) Be aware that any of the following can cause the glass to crack: because the upper and lower ceramic layers are shielded by low-melting glass:

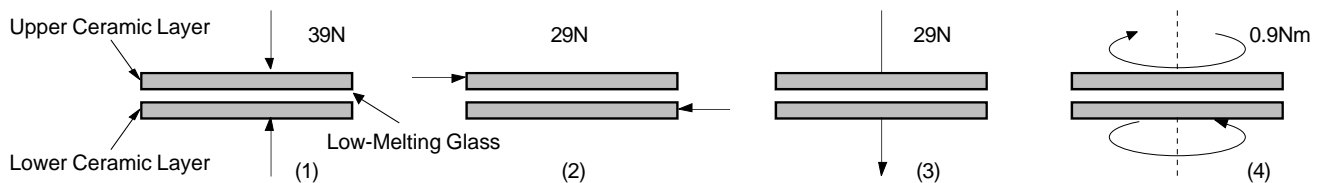

- (1) Applying repetitive bending stress to the external leads
- (2) Applying heat to the external leads for an extended period of time with a soldering iron
- (3) Rapid cooling or heating
- (4) Rapid cooling or impact to a limited portion of the low-melting glass with a small-tipped tool such as tweezers
- (5) Prying the upper or lower ceramic layers away at a support point of the low-melting glass

Note that the preceding notes should also be observed when removing a component from a board after it has already been soldered.

3) Soldering

- a) Make sure the package temperature does not exceed +80°C.
- b) Solder dipping in a mounting furnace causes damage to the glass as well as other defects. Use a grounded 30W soldering iron and solder each pin in less than 2 seconds. For repairs and remount, cool sufficiently.
- c) To dismount an imaging device, do not use solder suction equipment. When using an electric desoldering tool, ground the controller. For the control system, use a zero cross type

4) Dust and dirt protection

- a) Operate in clean environments.
- b) Do not touch glass plates by hand or have any object come in contact with glass surfaces. Should dirt stick to a glass surface, blow it off with an air blower. (For dirt stuck through static electricity ionized air is recommended.)
- c) Clean with a cotton swab and ethyl alcohol if the glass surface is grease stained. Be careful not to scratch the glass.

- 5) Exposure to high temperatures or humidity will affect the characteristics. Therefore, avoid storage or usage in such conditions.
- 6) CCD image sensors are precise optical equipment that should not be subjected to mechanical shocks.
- 7) Since the ILX522K has 2-line memory so that the signal of the R/B line is delayed, compress the optical system sub-scanning R/B line initially.

Package Outline Unit: mm

22pin DIP (400m il)

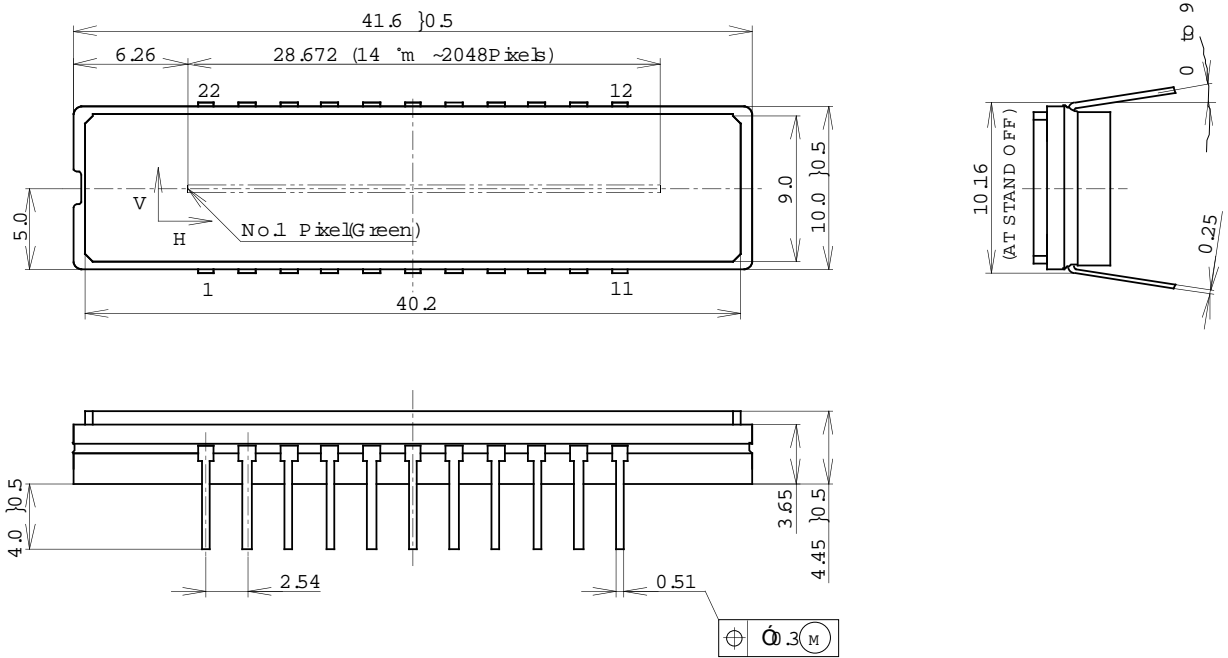

PACKAGE STRUCTURE

PACKAGE MATERIAL	CERDIP
LEAD TREATMENT	TIN PLATING
LEAD MATERIAL	42ALLOY
PACKAGE WEIGHT	5.2G

1. Distance of the first pixel (Green): (H, V) = (6.26 ± 0.8mm, 5.0 ± 0.5mm)
2. The height from the bottom to the sensor surface is 2.45 ± 0.3mm
3. The thickness of the cover glass is 0.8mm, and the refractive index is 1.5